

SEVERE DUTY COOLER

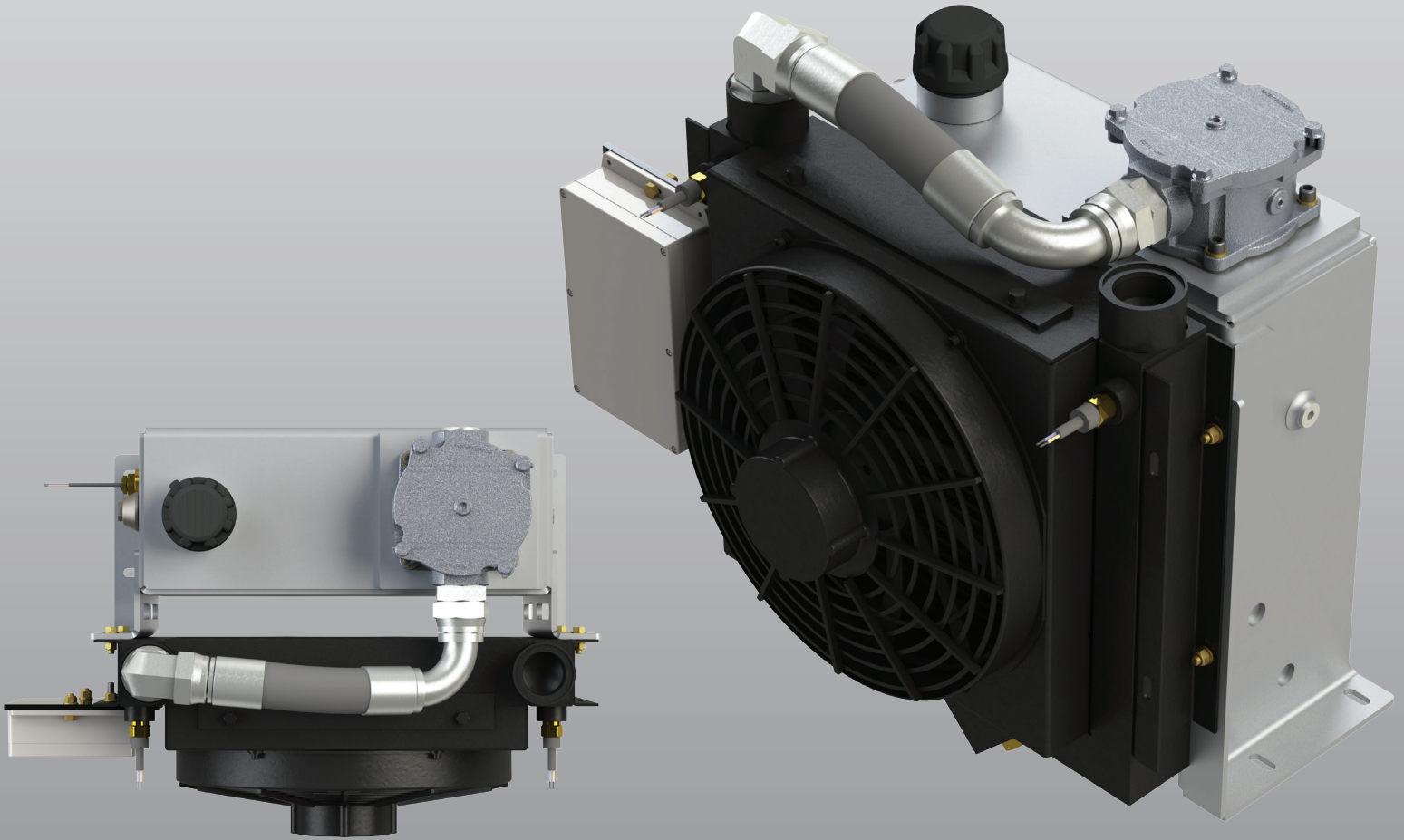

**IMPROVES COOLING BY
MORE THAN 200% OVER
COMPETITIVE MODELS**

*Built-in cold oil startup
& surge protection*

- ✓ *Improves flow rates to 60+ gpm at a nominal pressure loss*
- ✓ *8-gallon tank capacity – minimizes the risk of big spills*
- ✓ *Light-weight assembly - saves up to 400lbs compared to a 60-gallon tank*
- ✓ *Electric fan cooling for simplicity & cost-effectiveness*
- ✓ *Designed for tandem hydraulic pumps*
- ✓ *Custom tank configurations available*

*Dedicated to manufacturing quality equipment to make our
customers' lives easier. Imagine what Ledwell can do for you.*



Not just well made, **LEDWELL MADE.**

f t in y @

Texarkana, TX | ledwell.com
sales@ledwell.com | 888.533.9355

