

MAXTILT TRAILER

PREVENTATIVE MAINTENANCE

DAILY

- Running lights, brake lights, and turn signals
- Reflectors / conspicuity tape
- Tire pressure
- Condition of tires
- Condition of wheels
- Wheel nuts
- Oil in axle hubs
- Brakes working properly
- Electric and air connections
- Landing gear
- Mud flaps
- Floor
- Winch cable
- Frame & cross members

WEEKLY

- Lubricate tail and deck hinge points

MONTHLY

- Grease all zerks to include:**
Cylinder pins on H-lock, fold lock, fold linkage and tail
- Inspect cylinders for leaks
- Inspect all wiring, air lines & hydraulic lines
- Check winch cable
- Inspect trailer structure
- Condition of tires
- Inspect floor of trailer

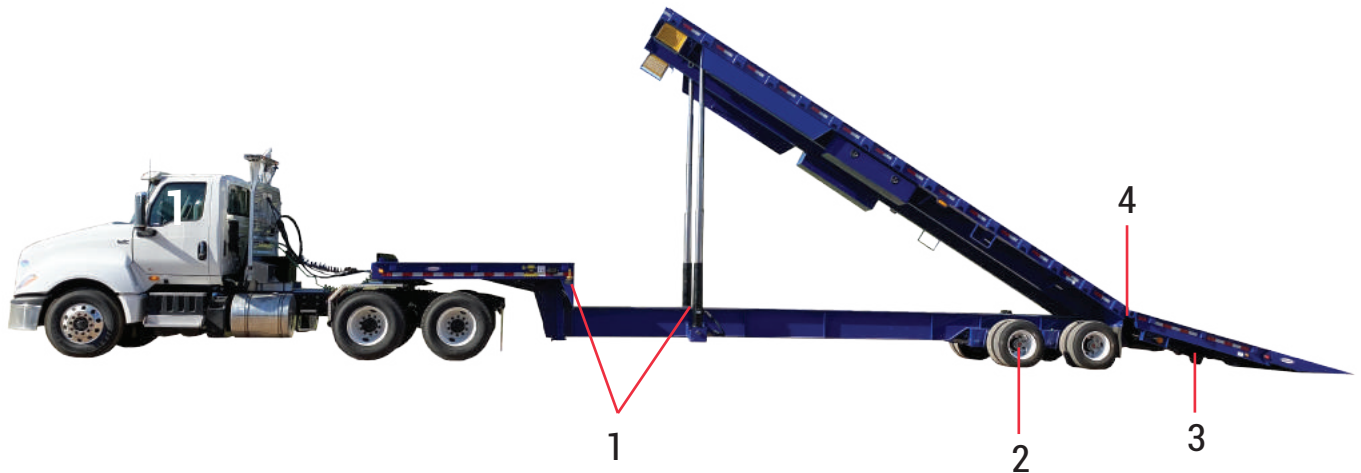

1. Grease mini-deck lift & lock assembly**
2. Check wheels for hub oil and grease slack adjusters
3. Grease H-lock assembly**
4. Apply lubrication to fold linkage assembly hinges

**Using GL2 grade grease



3300 Waco Street, Texarkana, TX 75501
888-LEDWELL | 903.838.6531
ledwell.com | service@ledwell.com

Not just well made, **LEDWELL MADE.**

